

**P**  
**ENNEKAMP**

MIDDLE EAST



**PENNEKAMP**  
MIDDLE EAST L.L.C

**WE KNOW THE REFRACTORY**

WHO WE ARE?

# About Our Company

## PENNEKAMP MIDDLE EAST LLC

PENNEKAMP MIDDLE EAST was established in 2008 aiming to perform end- to-end trading, technical activities and professional services in Dubai, UAE one of the most famous trading hubs in the world.

As a Refractory full service solution supplier to tailor the best solution for our customers, we supply over 50 types of Refractory products. The range from Refractory Raw materials such as bauxite, DBM, FM, SIC, Tabular Alumina, White fused Magnesia, Alumina Spinel, BFA, WFA, Mullite, Alumina Cement to the bricks and flow control products such as Slide Gate, Nozzle, Purging Plug, Stopper, Shroud , Masses and etc.

Every year we handle over 100,000 metric Tons of products to our customers all over the world. The more closely we work with our customers, the greater difference we can make for them. Our experienced experts and strong technical team support, with their open mind, keep making innovation and improvements for our customers with new technology.

Saving more purchasing costs for customers is growing in our mind, Therefore we cut every unnecessary cost for our customers to help them make smarter economical choices.

Customer-focused policy works as a driving force to keep pushing us to be more efficient in the Refractory industry. It helps us focus better to understand the concerns and work to be alert to new thinking and ideas that enable us to deliver better advice, service and solutions to our customers.

**We are always looking forward to build strong bonds with our customers, to provide change, benefit and better opportunities for them.**



# FINISHED PRODUCTS

CHARGE LADLE

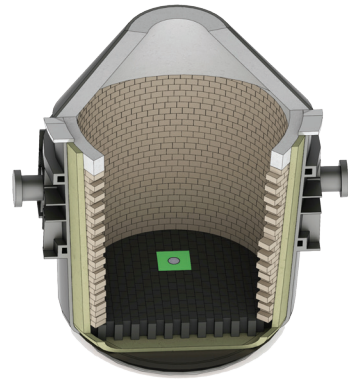

RUNNER

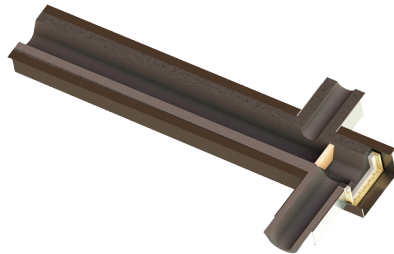

EAF

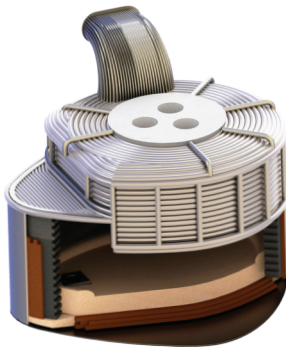

BOF

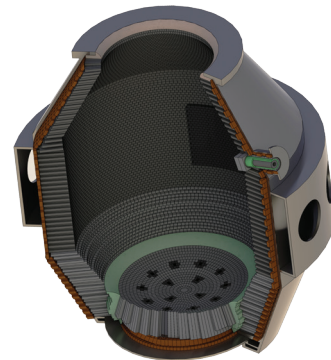

LADLE

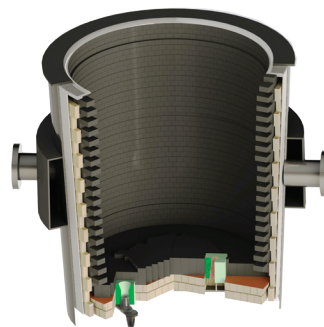

TUNDISH

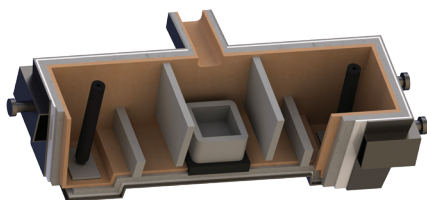

# FINISHED PRODUCTS



**As a Refractory full service supplier to tailor the best solution for our customers, we supply over 50 types of Refractory products.**



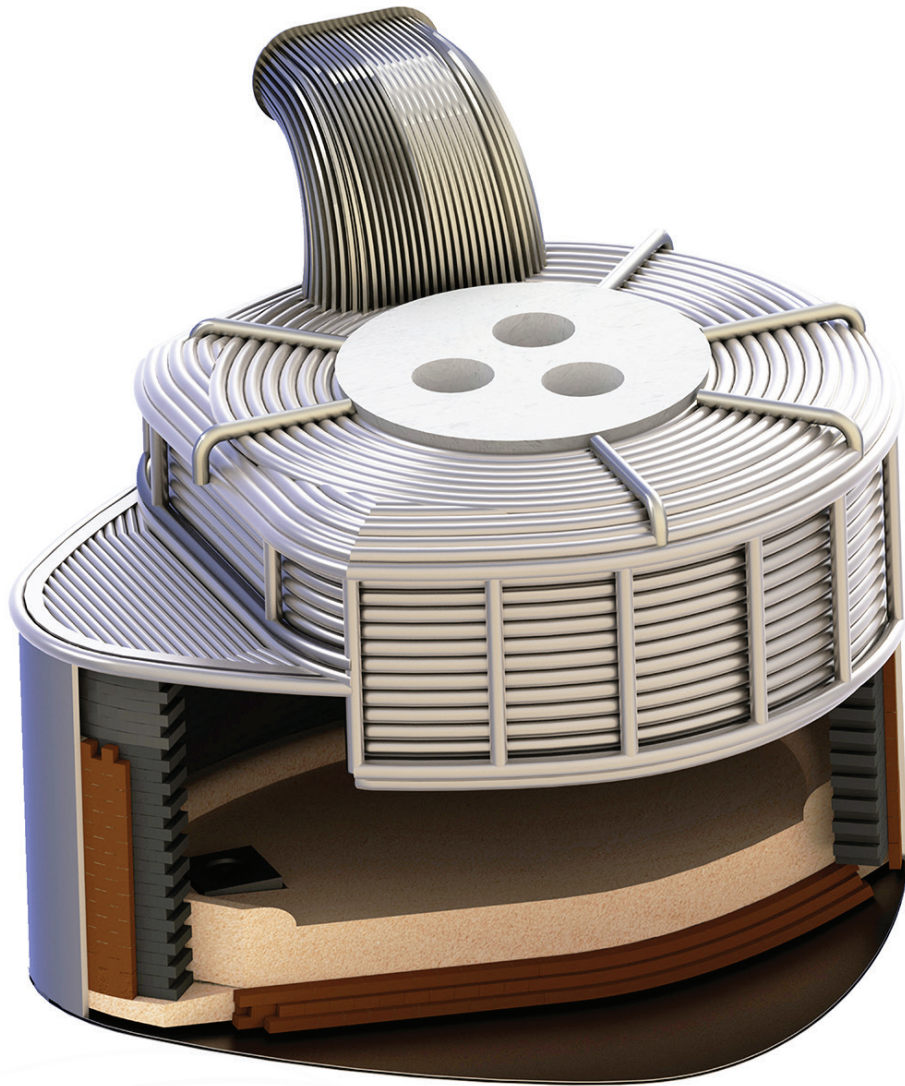

## Refractories for EAF

- ◆ Hot Repair Masses for EAF Tap Hole and Bottom
- ◆ Dry Ramming Masses for EAF Bottom
- ◆ EAF Tap-Hole Blocks
- ◆ High Aluminum Bricks
- ◆ MgO-C Brick for EAF
- ◆ Gunning Mixes for EAF
- ◆ EAF Tap Hole Filling Mass
- ◆ EAF Delta & Refining Furnace Roof
- ◆ Purging Plug for EAF

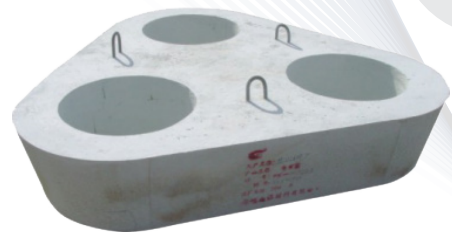

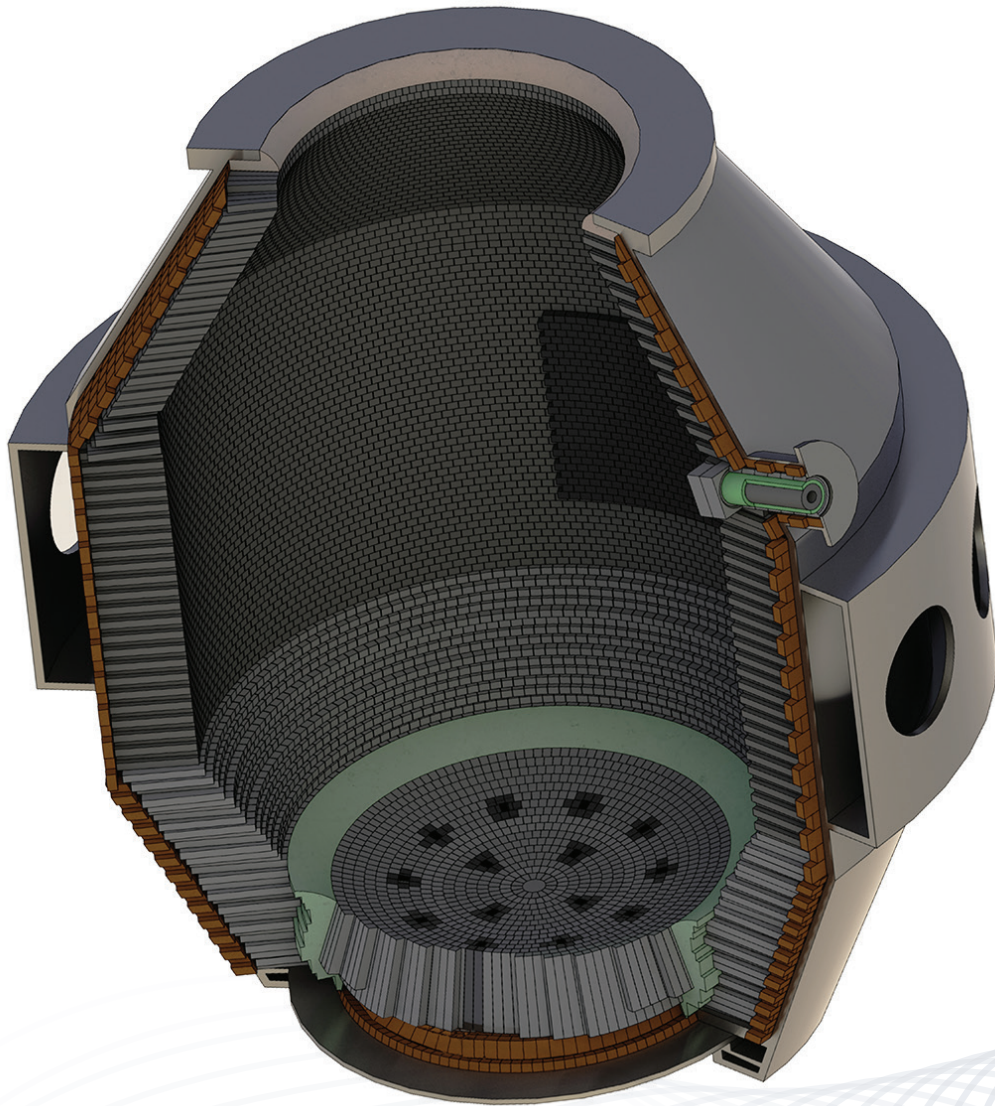



# Refractories for BOF

- ◆ MgO-C Bricks for BOF
- ◆ Tap Hole for BOF
- ◆ Slag splashing for BOF
- ◆ Large surface repairing Mix for BOF
- ◆ Purging Plug for Converter
- ◆ MgO-C Brick ss for Converter
- ◆ Tap-Hole Blocks for Converter
- ◆ Slag Ball
- ◆ Slag Limiting Dart
- ◆ Hot-Repair Mixes for Converter
- ◆ Gunning Mixes for Converter
- ◆ Magnesia-alumina Based Ramming Mixes
- ◆ Alumina-magnesia Based Ramming Mixes
- ◆ Converter Tap Hole Sliding Gate System
- ◆ Inner Nozzle
- ◆ Sliding plates for Converter
- ◆ Outer Nozzles

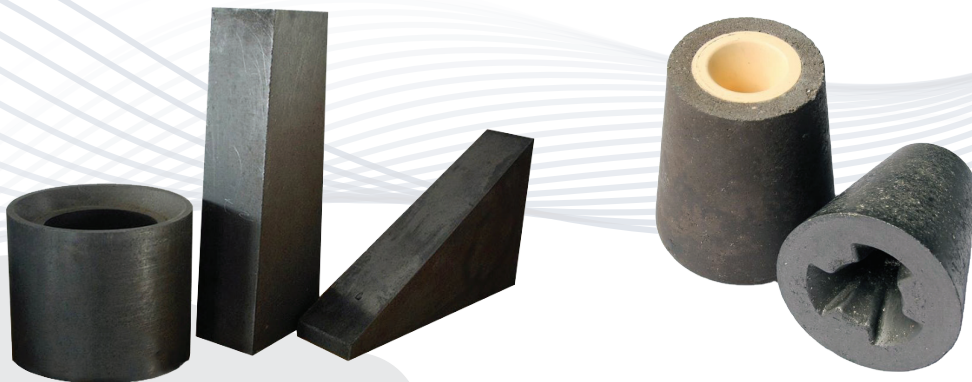

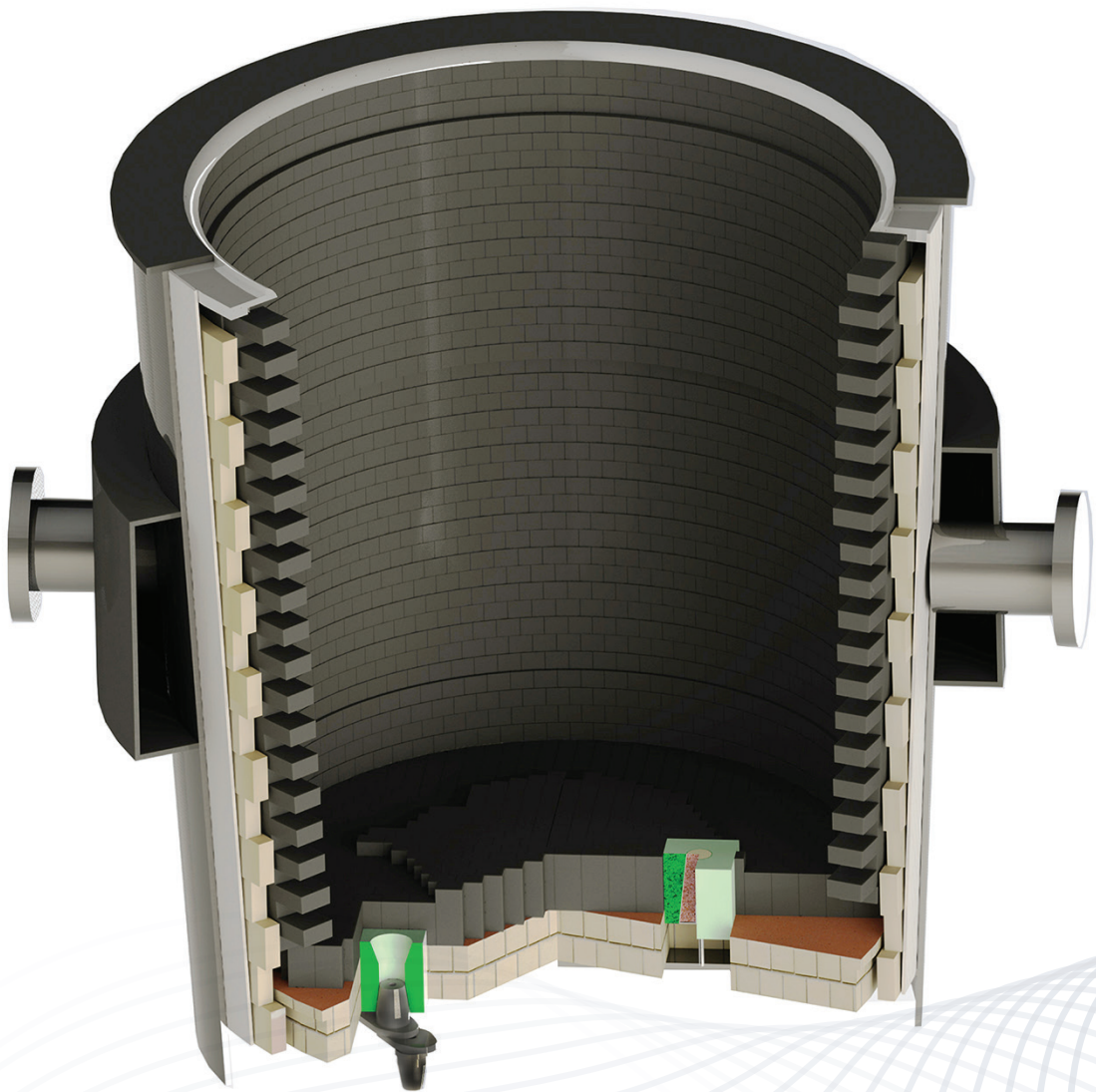

# Refractories for LADLE FURNACE

- ◆ Alumina MgO-C Bricks for Ladle Furnace
- ◆ Ramming Masses for Ladle Furnace
- ◆ MgO-C Bricks for Ladle Furnace
- ◆ MgO-Chrome Bricks
- ◆ Argon Lance for Ladle Furnace
- ◆ Tapping Sand for Ladle Furnace
- ◆ High Performance Slide Gate Plates
- ◆ Collector Nozzles
- ◆ Semi Nozzle
- ◆ Well Blocks for Inner Nozzles
- ◆ Purging Plugs & Porous Plugs
- ◆ Refractory Mortar
- ◆ Gunning Mixes for Ladle
- ◆ Alumina-Magnesia Ramming Mixes
- ◆ High Aluminum/Mullite Castables for Ladle

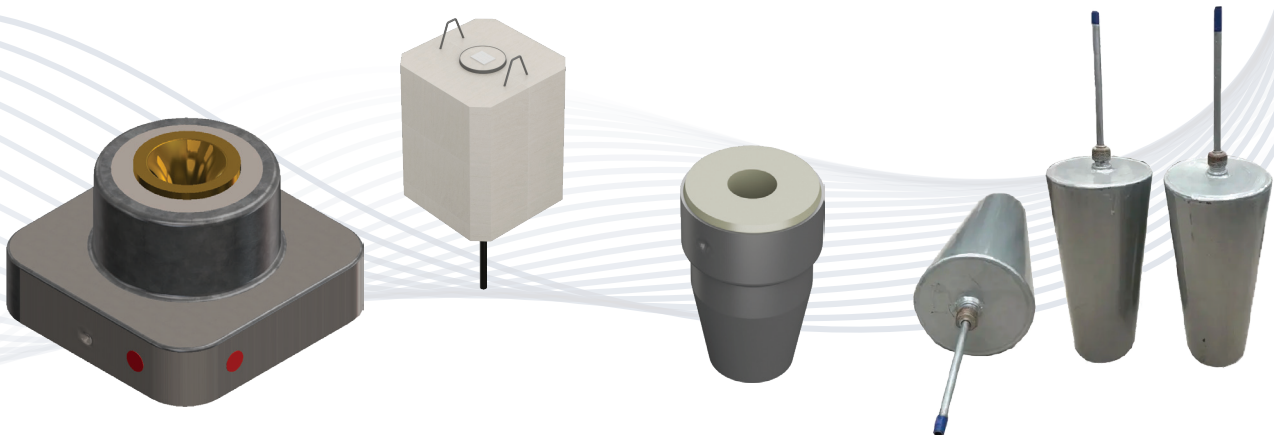
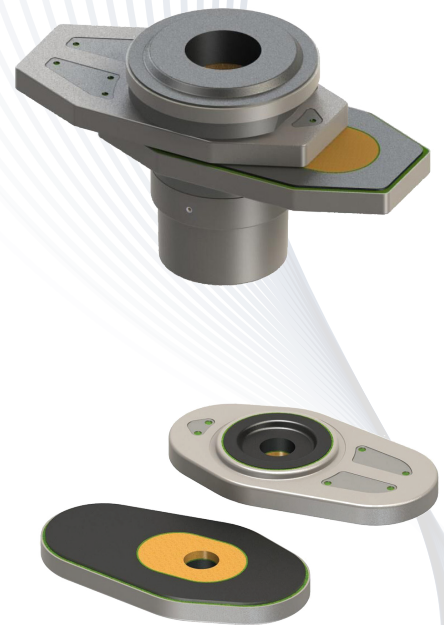

# CHARGE LADLE

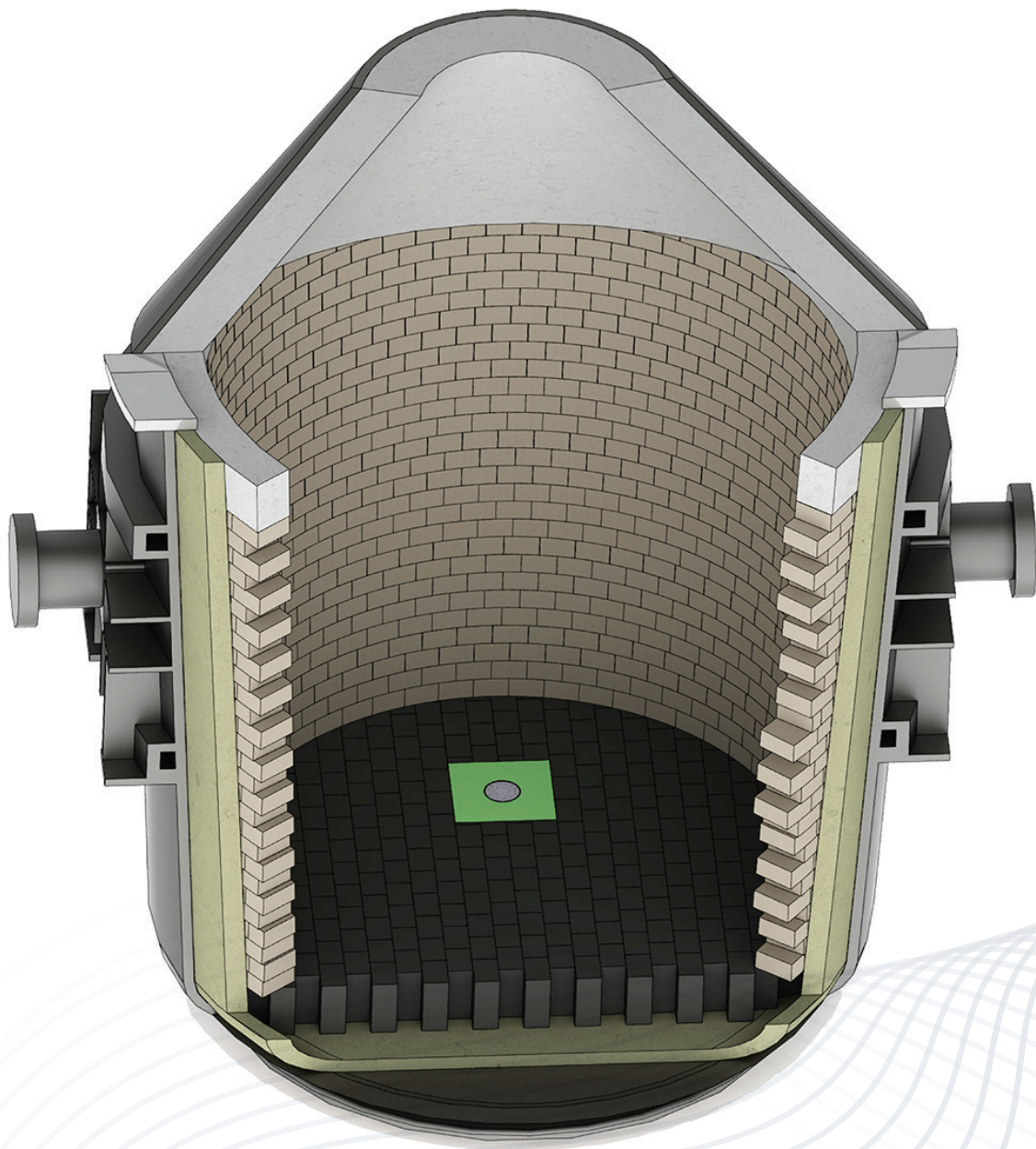

## Refractories for CHARGE LADLE

- ◆ Castable for Charge Ladle
- ◆ Alumina MgO-C Bricks for Charge Ladle
- ◆ Working layer Bricks for Charge Ladle
- ◆ Purging Plugs & Porous Plugs
- ◆ Hot Spray Mix for Charge Ladle
- ◆ Intergral Castables for Iron Mixer Furnace
- ◆ Castable for Torpedo and Iron Mixer Furnace

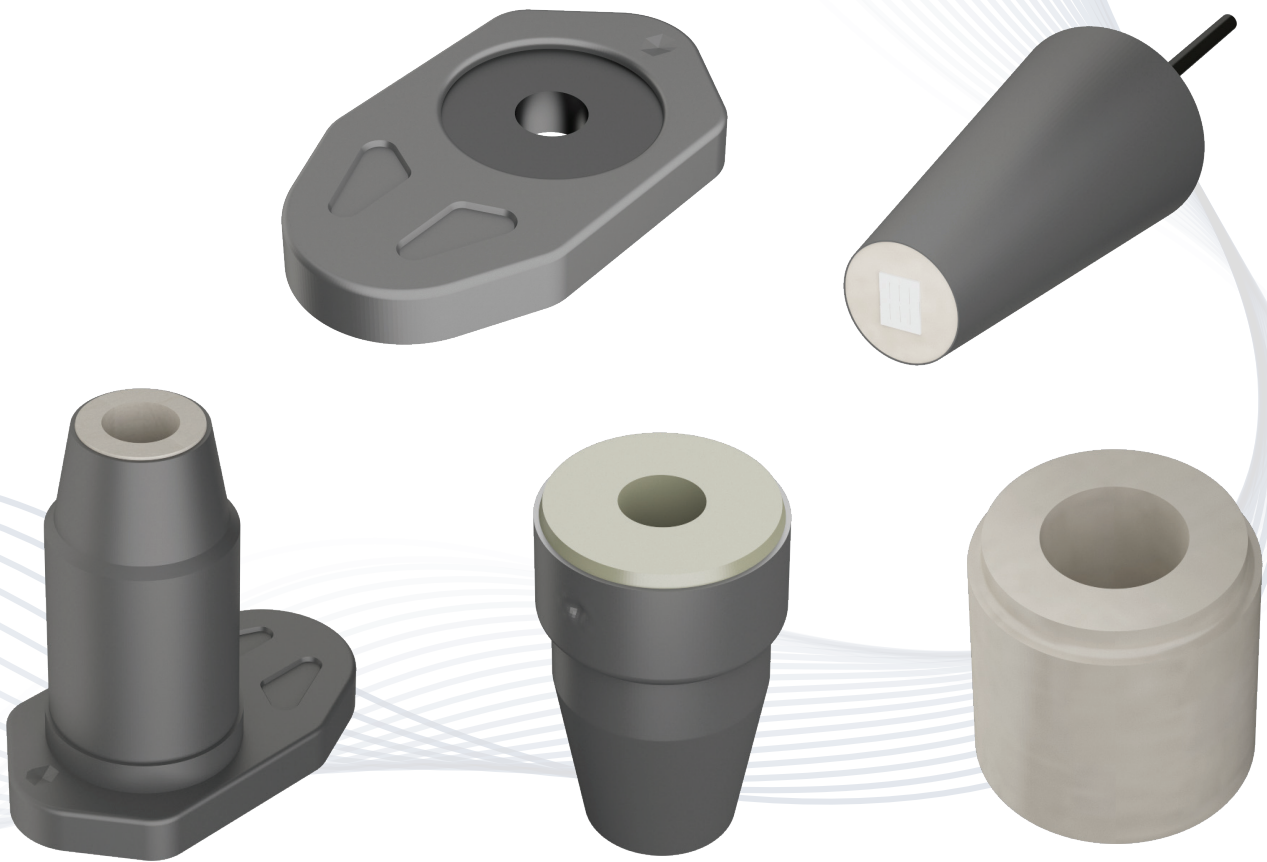

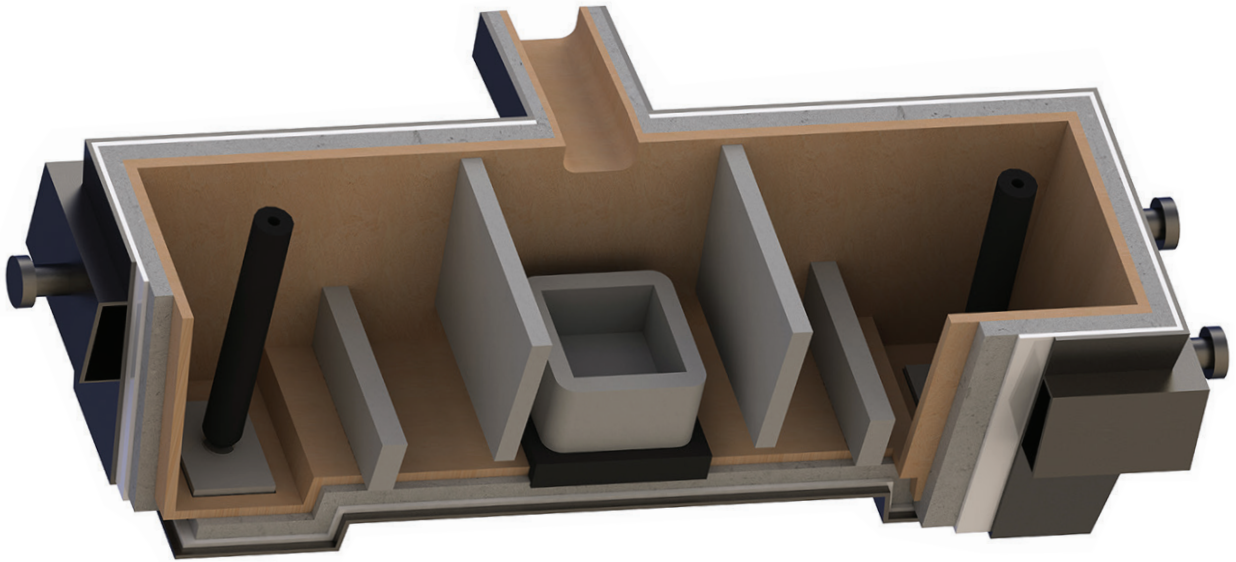

## Refractories for TUNDISH

- ◆ Ladle Shroud
- ◆ Monoblock Stopper Rods
- ◆ Submerged Entry Nozzle (SEN)
- ◆ Tundish Upper Nozzle
- ◆ Tundish Porous Upper Nozzle
- ◆ Tundish Nozzle with ZrO<sub>2</sub> Insert
- ◆ Tundish Porous Well Block
- ◆ Tundish Dry Vibration Mixes
- ◆ Light-weight Spraying Mixes for Tundish
- ◆ Tundish Spray Mixes, Phosphorus Free Spray Mixes



**We specialize in Refractory Raw Materials and  
Finished Products in steel, Ceramic and  
Polishing industry.**



**PENNEKAMP MIDDLE EAST L.L.C.**

 Office 30C-09 , I-Rise Tower,  
Barsha Heights (TECOM),  
Dubai , UAE

 [info@pennekamp-me.ae](mailto:info@pennekamp-me.ae)

 [www.pennekamp-me.ae](http://www.pennekamp-me.ae)

 +971 4 5646 977

 +971 4 564 6979